



INNOVATION WORKING FOR YOU

**TP50
Trail-Pro
Operator's and Parts Manual**



REIST Industries Inc.
100 Union Street
Elmira, Ontario, Canada
N3B 3L7

Phone: 519-669-1501
Fax: 519-669-3021
Toll Free: 1-877-467-3478
www.reistindustries.com

Effective Serial Number T3146

Contents

INTRODUCTION.....	4
PRODUCT CONFIGURATION	5
GENERAL SAFETY PRECAUTIONS	6
OPERATION AND TRANSPORTATION ON PUBLIC ROADS AND AREAS	7
SAFETY SIGN LOCATION	8
SETUP INSTRUCTIONS	9
MAINTENANCE	10
USE OF TRAILPRO	11
POSITIONING:	11
STARTING THE TRAILPRO:.....	11
STOPPING MACHINE:.....	11
GROUND SPEED:.....	11
DISC ADJUSTMENTS:.....	12
OPERATIONAL HINTS.....	12
Important Note:	12
LEVELING BLADE & CUTTING EDGE REPLACEMENT:.....	12
PARTS	15
Disc Mounts	15
Rubber Flaps & Slider Plate.....	15
Cutting Edges.....	16
Drive Parts	17
Drive Parts – Parts List	19
Disc Left.....	20
Disc Right.....	20
Stone Guard Screen	22
Optional Rear Gauge Roller.....	23

Record your product information for future reference:

Model Number: _____

Serial Number: _____

In Service Date: _____

Sold By: _____

INTRODUCTION

Thank you for choosing the REIST TRAILPRO.

We feel confident that this equipment will meet your expectations in workmanship, reliability and performance when used as designed. This manual is to assist you with the safe operation of the REIST TRAILPRO. It also has a parts list to help you when replacement parts are required. Any person who will be assembling, attaching, maintaining, or operating this product and the prime mover to which it is attached, are required to read and completely understand the information and instructions contained in this manual and that of the prime mover. Always obtain further assistance by contacting the dealer from which this product was purchased or by contacting REIST Industries at the telephone number or address below. Keep this manual available for reference whenever this product is being handled or used and we recommend that it is reviewed periodically and before seasonal use. Provide this manual to any new owners and/or operators and ensure they fully understand the safe operation of this equipment before it is placed in service.

Replacement copies of this manual are available for downloading at:
www.reistindustries.com

Innovation Working For You

REIST Industries Inc.

100 Union Street
Elmira, Ontario, Canada
N3B 3L7

Phone: 519-669-1501
Fax: 519-669-3021
Toll Free: 1-877-467-3478

The illustrations and information contained within this manual were current at the time of publication. Under our policy of continuous improvement, we reserve the right to change specifications and designs without prior notice. The illustrations do not necessarily show the standard version of product offered by REIST Industries.

PRODUCT CONFIGURATION

To ensure that the right size of TRAILPRO is matched to the prime mover, REIST Industries TRAILPRO is sized as follows:

TRAILPRO

- Model TP50 - 50" wide, PTO 540, Weight 1250 lb (570 kg), Input 35 -55 hp, using a CAT I Hitch mount



WARNING!

Exceeding the recommended specifications can result in damage to the equipment and will void all REIST Industries warranties.

The TRAILPRO is PTO driven.

The following references are used throughout this Operator's and Parts Manual:

Front or Rear Mounted	Orientation that is determined in relation to the operator of the equipment when seated in the normal operating position of the prime mover
Right, Left, Front, Rear	Orientation that is determined in relation to the operator of the equipment when seated in the normal operating position of the prime mover.
Attachment, Implement	Refers to the TRAILPRO whether attached or separate from the prime mover
Prime Mover	The engine-driven machine to which this product is attached
Equipment	Refers to the Implement and or prime mover whether separate or connected
WARNING, DANGER, IMPORTANT	A notice that relates to the safe and efficient operation of the TRAILPRO or prime mover. Read and understand the reference before attaching or operating the TRAILPRO or the prime mover.

GENERAL SAFETY PRECAUTIONS

Careful operation is the best assurance against accidents. It is the owner's responsibility to make sure that all operators read and understand this manual and follow the recommendations, cautions and warnings before connecting to a prime mover and operating the equipment. The REIST TRAILPRO was designed for use to grade and level trails with stone dust, gravel or similar product.

Familiarize yourself with all controls and know how to quickly stop the equipment and all rotating parts in the case of an emergency.

Never let an untrained person or a child operate equipment.



WARNING!

DO NOT MODIFY THE TRAILPRO OR PRIME MOVER

Modifications may weaken the integrity of the TRAILPRO and may impair the operation, safety, and performance of the product. When making repairs, only qualified technicians using the manufacturer's genuine parts, following authorized instructions, shall attempt the repair. Never modify any ROPS (Roll Over Protection Structure) or FOPS (Falling Object Protective Structure) equipment or other safety device or remove guarding. Any modifications must be sanctioned in writing by an authorized representative of the manufacturer.



WARNING!

MAINTAIN AND REPAIR EQUIPMENT SAFELY

- Do not wear loose clothing, or any accessories that can catch in moving parts
- If you have long hair, cover or secure it so that it does not become entangled in the equipment
- Work on a level surface in a well-lit area.
- Always lower raised equipment to the ground or securely support it to prevent unintentional movement
- Remove and retain the prime mover's ignition key
- Use the correct tool for the job at hand. Make sure they are in good condition for the task required
- Wear the protective equipment specified by the tool manufacturer
- Use care when working on hydraulic systems and understand how to check for and release trapped hydraulic pressure



WARNING!

STAY CLEAR OF ROTATING OBJECTS

Keep hands, feet and clothing away from power driven rotating parts.

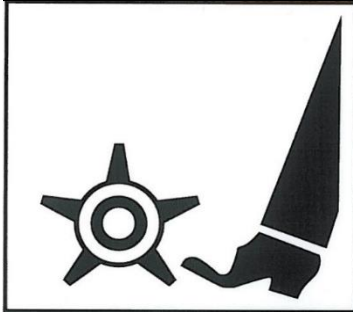

Never use your hands to clear if clogged. Never allow anyone to reach into the rotor housing. The rotor can crush and/or dismember. Keep everyone clear of the rotor until the prime mover engine is off and the hydraulic pressure has been relieved.

OPERATION AND TRANSPORTATION ON PUBLIC ROADS AND AREAS

Always adhere to the local laws and regulations concerning traveling or operating on public roadways and areas. Clean all lights, reflectors and mirrors ensuring that all lighting is in working order before moving. Know the area! i.e. Tail widths, elevations, steep side drop offs. Watch out for pedestrians and use caution when approaching pedestrians, hazardous objects (stones, etc.) may inadvertently be discharged. Do not engage or disengage the PTO while roading. Always be alert while transporting or operating the equipment. Select a safe ground speed when transporting from one area to another. When operating, or driving on roadways, travel in such a way that faster moving vehicles may pass you safely.

SAFETY SIGN LOCATION

Contact REIST Industries if replacement safety signs are required.

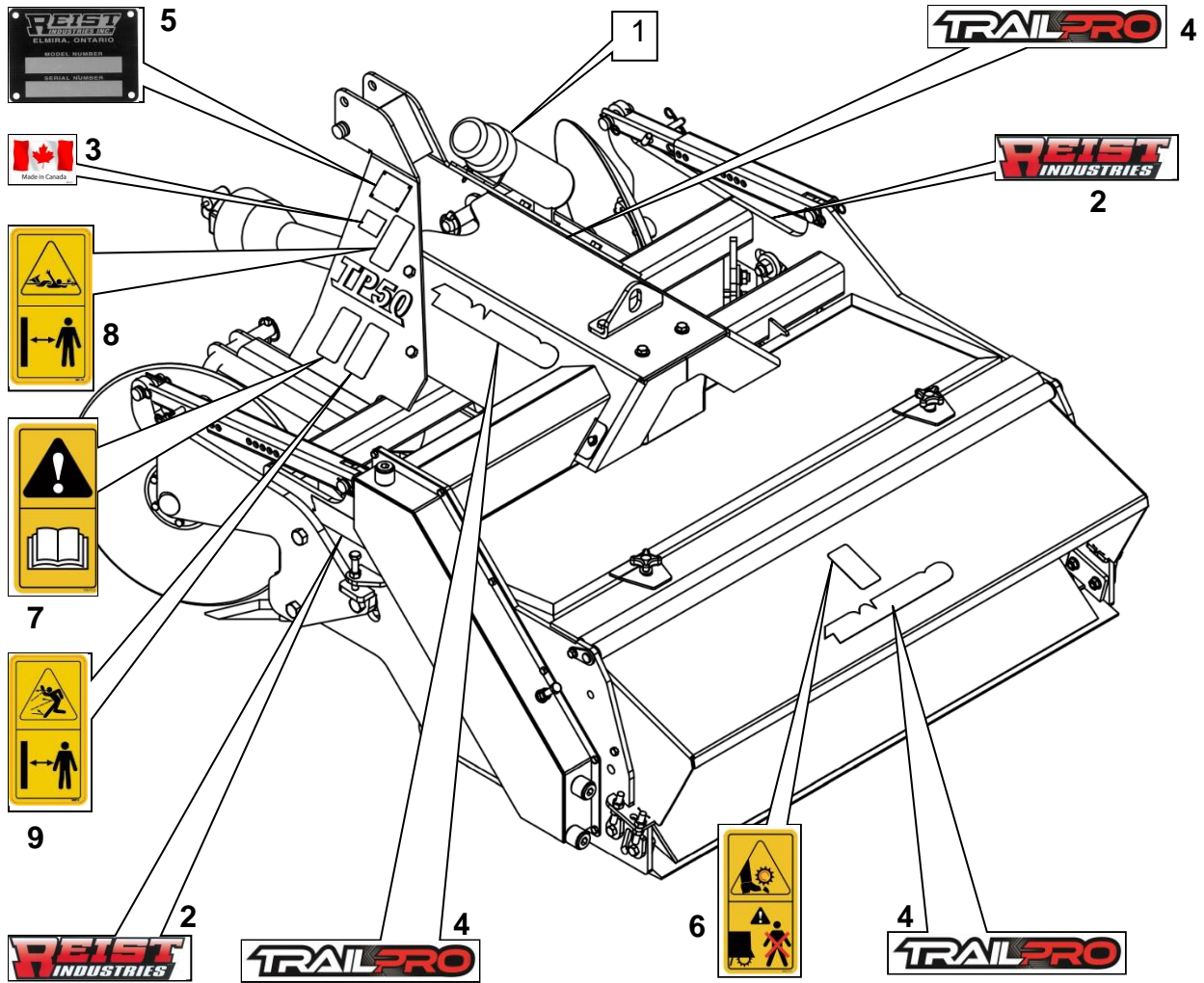

Parts List			
ITEM	QTY	PART NUMBER	DESCRIPTION
1	1	67.222.000	Manual Holder
2	2	RD106	Reist Decal
3	1	RD115	Made In Canada Decal
4	3	RD130	Trail-Pro Decal
5	1	Serial	Serial # Plate
6	1	WD111	Danger to Feet - Stay Clear of Front! Decal
7	1	WD112	WARNING - Read Manual Decal
8	2	WD114	DANGER Rotating Drive Line Decal
9	1	WD116	WARNING Flying Object Decal

SETUP INSTRUCTIONS

Improper installation, operation, or maintenance of this equipment could result in serious injury or death. FOLLOW ALL SAFETY INSTRUCTIONS IN THIS MANUAL AND THE PRIME MOVER'S MANUAL(S).

Refer to the operator's manual(s) for your prime mover and follow the mounting instructions contained therein.

Once attached, and it is safe to do so, carefully raise the TRAILPRO and engage PTO to check clearances and to verify that all mounting procedures have been successfully completed.

Note a 540 rpm PTO drive has 6 splines or teeth and is 1 $\frac{3}{8}$ inch in diameter.



WARNING!

STAY CLEAR OF ROTATING OBJECTS

Keep hands, feet and clothing away from power driven rotating parts.

The TRAILPRO hitch is a category One. Use the proper pin sizes when attaching the TRAILPRO to the prime mover. Do not attach the PTO driveline at this time.

- a. Always ensure that the PTO shaft is proper length! Make sure PTO shaft doesn't bottom out or come apart throughout the range of movement for the 3 PTH.
- b. Connect the TRAILPRO to the lower arms of the 3-point hitch. Be sure the 3-point hitch is set in the non-sway position (See prime mover manual for details)
- c. Measure the distance from the end of the prime mover PTO shaft to the end of the gear box shaft on the TRAILPRO
- d. Lay driveline on flat surface and measure the distance from one end to the other in the most collapsed position
- e. If distance from the end of the prime mover PTO shaft to the end of the gear box shaft on the TRAILPRO is greater than 9" more than the overall length of the collapsed driveline, the driveline may be too short. When the PTO shaft is at the longest position there should be a minimum of 3" overlap.
- f. Once the driveline is installed, connect the upper link
- g. When it is safe to do so, slowly lift the TRAILPRO thru the complete arc of the 3-point mount. Make sure driveline does not bottom out at anytime throughout the arc. Make sure the driveline shields are in place and do not separate

MAINTENANCE

Refer to the General Safety Precautions, page 6 of this manual before performing any maintenance.

1. Always ensure the TRAILPRO is properly installed, the prime mover is positioned on a level surface with the park brake set and the TRAILPRO positioned on the ground
2. Shut-off the engine and remove and retain the ignition key
3. Chock the wheels to prevent movement and release residual hydraulic pressure
4. Grease bearings every 100 hrs with EP2. **Do Not Over Grease**
5. Check the chain tension adjustment every 50 hours to ensure that the chain [Item #2, below] does not have any slack. To check the backlash in a loose chain, turn off the Prime Mover, open the spiked roll shield, and then move the spiked roll back and forth by hand. If there is excessive movement the chain needs to be tightened. Loosen the nut [Item #1], then slowly turn the bolt [Item #3] clockwise while moving the spiked roll back and forth. When the backlash has been reduced, tighten the locknut.
6. Grease PTO crosses daily (or 8 hours of operation) with EP2 (PTO drive only)
7. At the beginning of each season, ensure that all fasteners are properly torqued, all safety guards are in place and that operator's manual is reviewed and understood
8. At the end of season, perform all maintenance activities greasing shafts and replacing gear box oil, cap and protect exposed hose ends (if so equipped) and the PTO drive splines. Always check for missing or damaged parts and repair as required

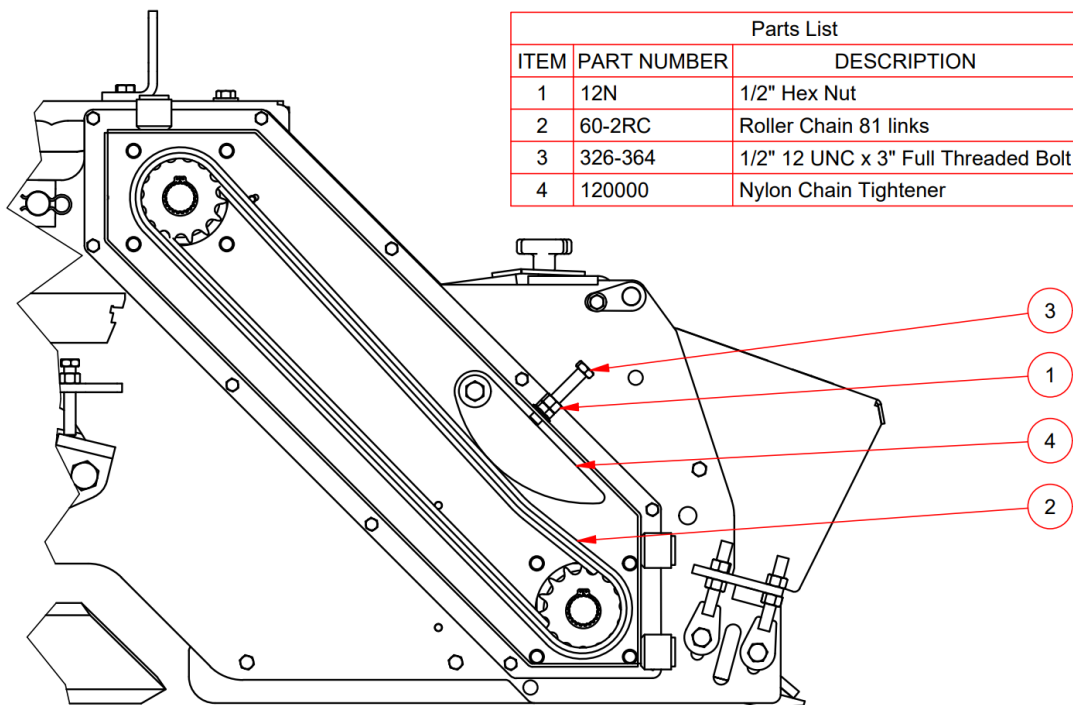

USE OF TRAILPRO

POSITIONING:

- Always use proper pin and bushing sizes when attaching TRAILPRO to tractor.
- Ensure that the TRAILPRO's cutting edge is parallel to the ground. If not, adjust the lift arms on the prime mover accordingly.
- Stabilized 3 PTH arms to centre.
- Check that when the TRAILPRO is sitting on a smooth surface, that there is **1/4" to 3/8"** clearance between carbide tips of the Rotor to the floor surface. Rear Leveling Blade needs to be adjusted as cutting edges and leveling blade wear.
- Lower TRAILPRO to ground, putting 3 PTH lever to max. down position.
- Adjust top link until cutting blade makes ground contact by 1/8 inch.
- With 3 PTH lever in max. down position start grading at 3 to 10 mph (5 to 15 km/h).
- Readjust top link to maintain an average cutting depth of 1/8 inch.

STARTING THE TRAILPRO:

- Be sure the area is clear of all bystanders
- Refer to the prime mover starting instructions
- Run the engine at low idle and slowly engage the PTO/hydraulic control
- Increase the prime mover engine RPM to achieve the rated PTO speed.

STOPPING MACHINE:

- Decrease engine speed to low idle
- Disengaging PTO/hydraulic drive
- Shut down the prime mover in accordance to instructions before getting off.

GROUND SPEED:

- Travel speed is governed by the condition of the trails or surface being graded. Generally, the faster the better. Preferred speed is 5 to 15 km per hour.
- The more grass on the trail the slower the speed. You might have to go down to a crawl when grading a trail for the first time. Especially if large amounts of sod is going through.
- It is the responsibility of the operator to note the condition of the job being done and set the speed to obtain the proper grading effect and safety.

DISC ADJUSTMENTS:

- The side discs cut and roll the sod into the grading area.
- The slider link is mainly used in the float setting but it also has several fixed position settings. The fixed positions are sometimes needed to cut into the sod.
- The ½” adjusting screw at the side is to limit the downward travel of the disc when the slider link is in the float position.
- The disc on the right-hand side is normally set approximately 1-1/2” below the point of the cutting edge.
- If the trail is the same width as the TRAILPRO the left-hand disc is set same as the right-hand side.
- But if the trail is wider then the TRAILPRO the left-hand disc is set to the same depth as the point of the cutting edge. This is to prevent a groove to be cut on the trail.
- If the TRAILPRO is being used to grade a parking lot, both sides need to be set no deeper than the point of the cutting edge.

The PTO driveline is equipped with a 8mm x 50mm shear bolt that protects the drive system components from shock loads if an obstruction gets into the rotor.

OPERATIONAL HINTS

- Adjust the top link so cutting edge is only cutting a small amount. (approx. 1/8”)
- Proper three-point hitch pin and bushing sizes are important
- In grassy or first time grading more than one pass might be necessary
- Adjust Speed for proper results. Sometimes slow works best, sometimes faster works better

Important Note:

The 3/8 x 2 Flat head bolts with lock nuts that attach the cutting blades to the adjustable segments of the main frame are also shear bolts. If the machine makes contact with a solid unmovable object these bolts will shear off and the cutting blades are detached from the machine. This will be a noticeable situation and you must stop and reattach the blade with new bolts that are supplied inside the manual holder. Once the blades are attached place the machine on a flat surface and check the blade adjustment as described on page 13 of your Operator’s and Parts Manual.

LEVELING BLADE & CUTTING EDGE REPLACEMENT:

To replace cutting edges and leveling blades use a hard, smooth, and level surface.

1. Under the carbide tip of rotor, place a 3/8" object such as plywood or bar stock.
2. Make sure rotor is turned so the carbide tip is at lowest position.
3. Place a stand under hitch approx. 14-1/4" high.
4. Replace rear leveling blade and adjust with adjusters so it touches floor surface.
5. Replace center cutting edge and adjust with adjusters so it touches floor surface.
6. To level center cutting edge horizontally, sim washers might have to be added between the plate. Either to the top hole or to the lower two holes.
7. Side cutting edges are attached with 3/8x2 flat head bolts.
8. Then with the cutting edges sitting on the floor surface lightly tighten the 5/8x2 bolts.
9. When finished, all leveling blades and cutting edges need to touching the floor surface and not more then a 1/16 clearance.
10. Tighten all bolts.

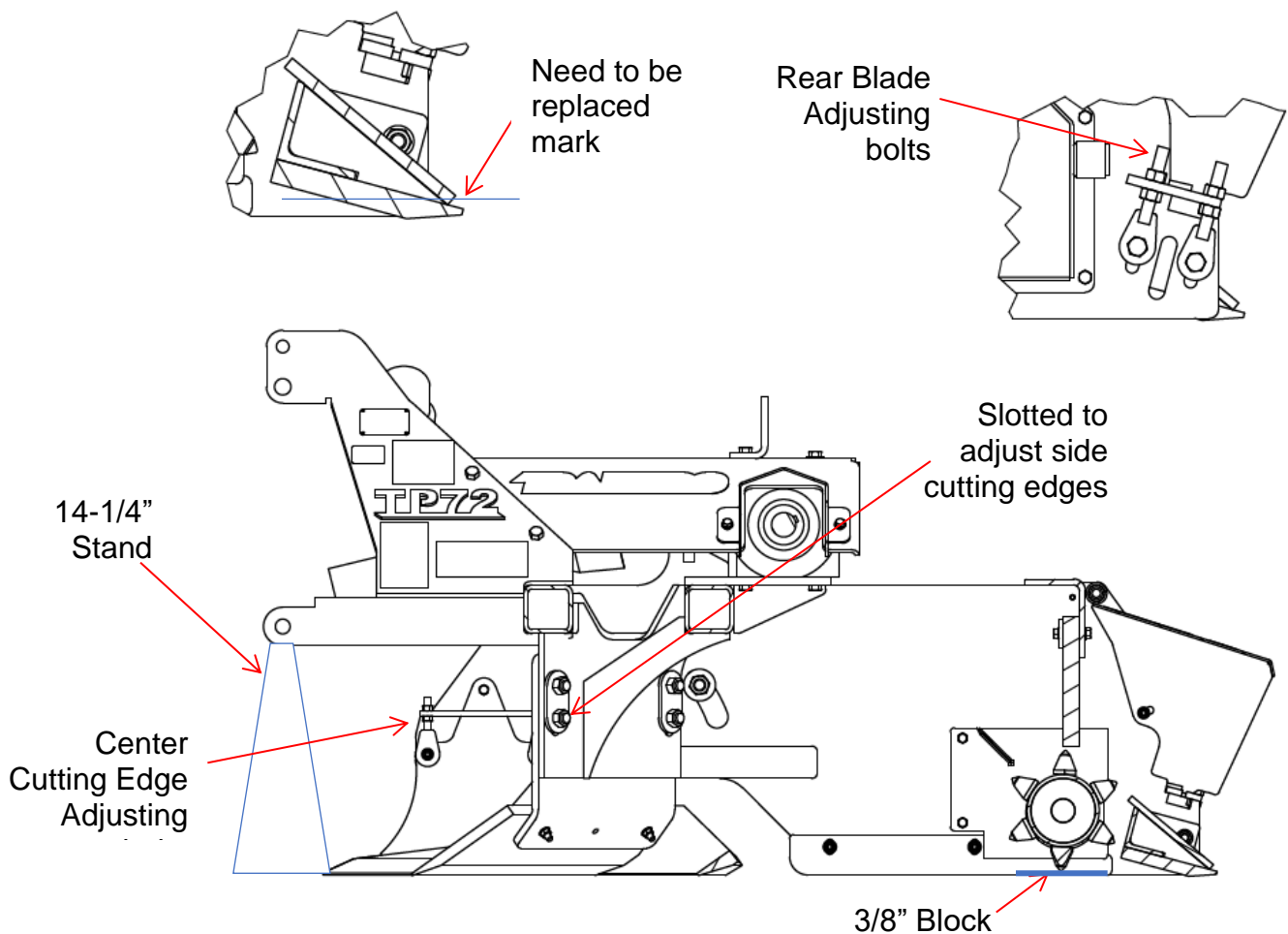



WARNING!

READ OPERATOR'S MANUAL BEFORE OPERATING

Do not operate equipment until you are completely trained by a qualified operator in how to use the controls, understand the machine's capabilities, dimensions, and all safety requirements. Refer to your operator's manual for these instructions.

- Do not operate an engine in confined or non-ventilated area
- Do not perform adjustments or repairs with the engine running
- Always lower raised equipment to the ground or securely support it to prevent unintentional movement
- Do not operate on excessive inclines or side slopes – know the limitations of the prime mover – be careful when turning on slopes as a rollover condition may exist
- Never carry passengers
- Keep bystanders away from the machine when in operation
- Be aware of pedestrians
- Know how to quickly stop the equipment and all rotating parts in the case of an emergency
- Stop the prime mover, lower implements and turn off the engine before dismounting
- Refer to the prime mover's Operator's Manual for additional information

PARTS

Disc Mounts

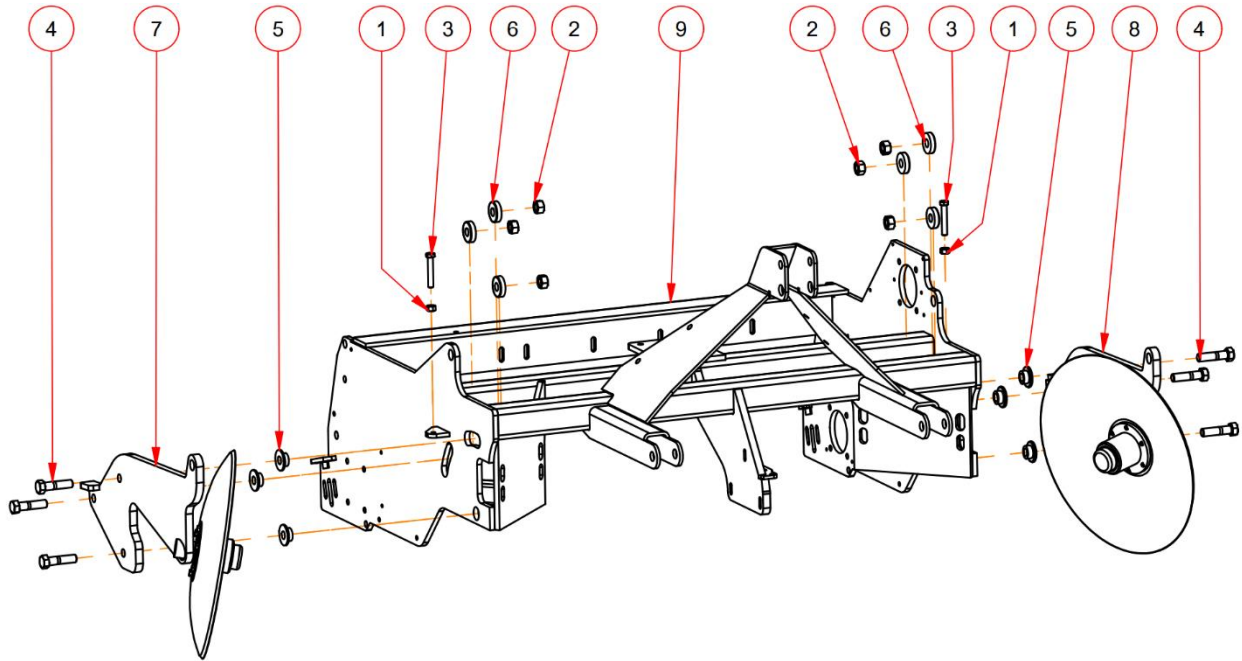

Parts List			
ITEM	QTY	PART NUMBER	DESCRIPTION
1	11	12N	Hex Nut
2	6	34N	Hex Nut
3	3	326-364	1/2x3 Full Threaded Bolt
4	6	343	Hex Bolt
5	6	108940	Bushing 34_114
6	6	108941	Washer
7	1	109388	Disc Arm Assembly Right
8	1	109389	Disc Arm Assembly Left
9	1	116398	Trail Pro Weldment 50

Rubber Flaps & Slider Plate

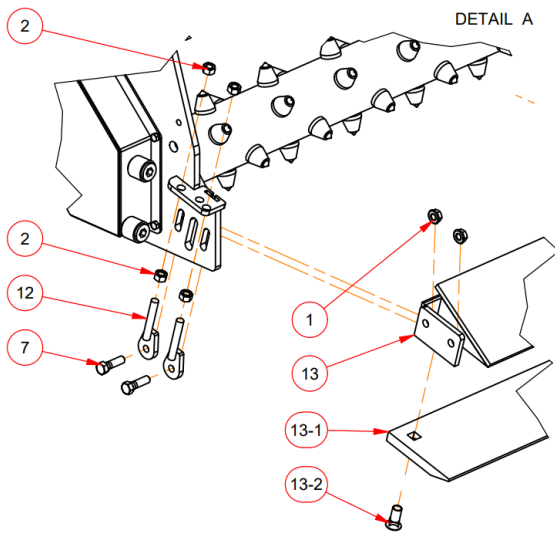
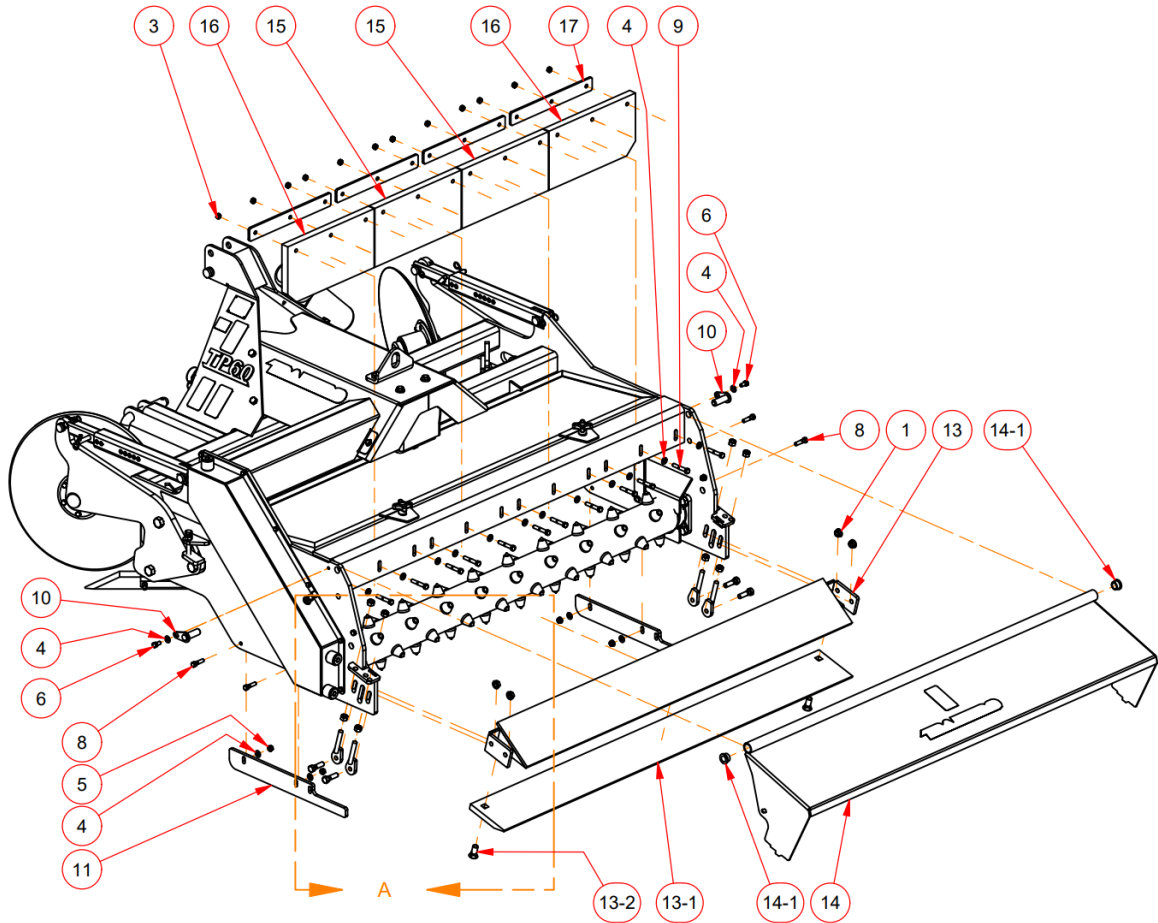

Parts List

ITEM	QTY	PART NUMBER	DESCRIPTION
1	4	12FSLN	Flange Nut
2	8	12N	Hex Nut
3	12	38CLN	NC Lock Nut
4	18	38FL	BP Flat Washer
5	4	38FSLN	Flange Nut
6	2	3834	Hex Bolt
7	4	12134	Hex Bolt
8	4	38112	Hex Bolt
9	12	38214	Hex Bolt
10	2	108075	Gate Pin
11	2	109579	Keeper Plate
12	4	110278	Adjuster
13	2	116417	Cutting Edge Weldment 60
13-1	1	116423	Cutting Edge 3/4 x 6 x 60
13-2	2	5823PB	5/8 x 1-1/2 Plow Bolt
14	1	116420	Shield 60
14-1	2	MFI-1216-10	Igus bushing
15	2	116436	Rubber 60
16	2	116437	Rubber End 60
17	4	116500	Rubber Keeper Plate

Cutting Edges

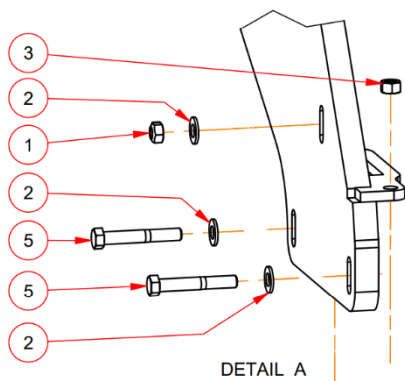
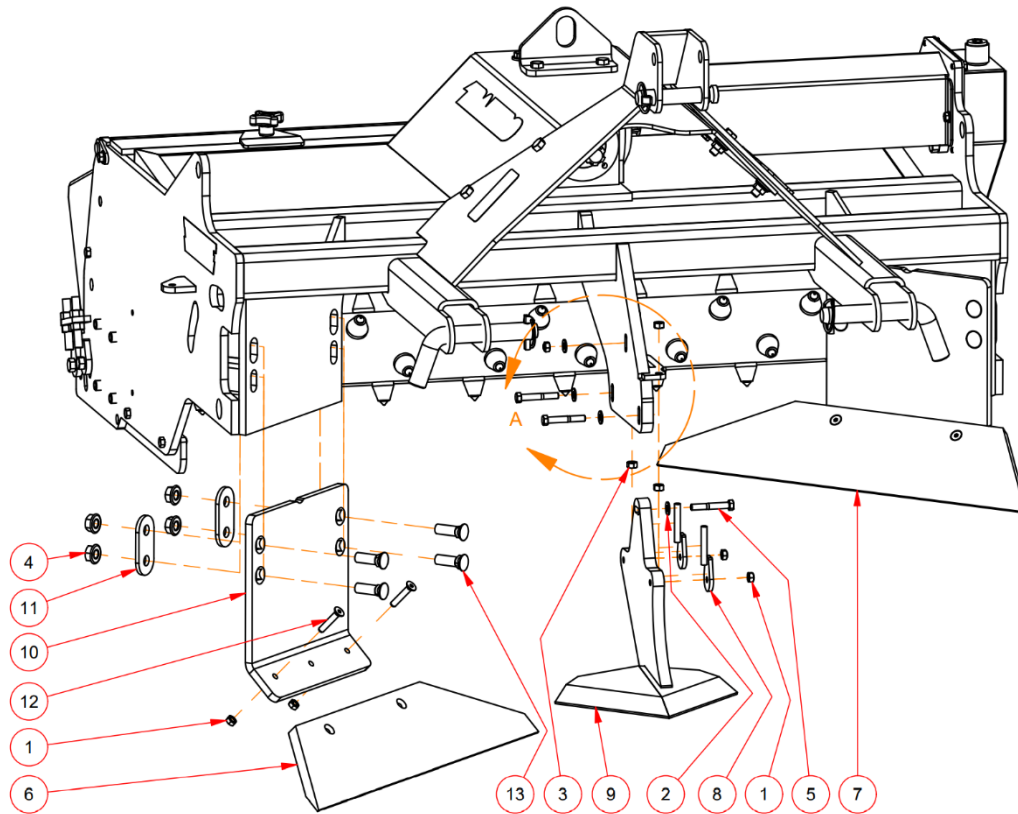

Parts List			
ITEM	QTY	PART NUMBER	DESCRIPTION
1	7	38CLN	NC Lock Nut
2	4	38FL	BP Flat Washer
3	4	38N	Hex Nut
4	8	58FSLN	Flange Nut
5	3	38212	Hex Bolt
6	1	108847	Cutting Edge Outside
7	1	108853	Cutting Edge Outside Left
8	2	108926	Adjuster
9	1	109574	Center Cutting Edge
10	2	109692	Cutting Edge Mount Lower
11	4	109714	Bolt Plate
12	4	ANSI B18.3 - 3/8-16 UNC x 2	Hexagon Socket Flat Countersunk Head Cap Screw
13	8	PB058200	5/8 x2 Plow Bolt

Drive Parts

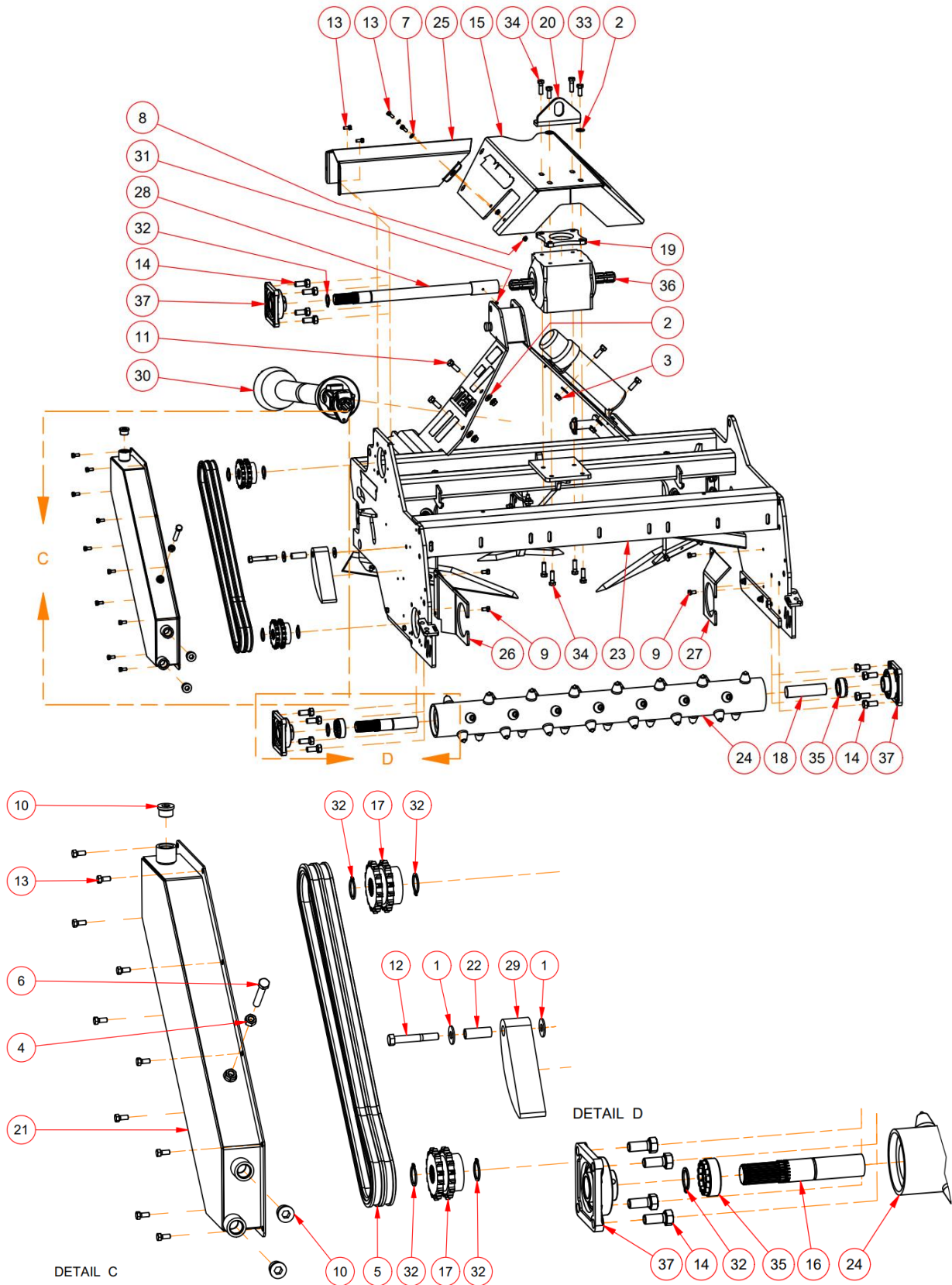

Drive Parts – Parts List

Parts List			
ITEM	QTY	PART NUMBER	DESCRIPTION
1	2	12F	Flat Washer
2	6	12FL	BP Flat Washer
3	8	12FSLN	Flange Nut
4	11	12N	Hex Nut
5	1	60-2RC	Roller Chain 81 links
6	3	326-364	1/2x3 Full Threaded Bolt
7	4	516FL	BP Flat Washer
8	2	516FSLN	Flange Nut
9	6	3834	Hex Bolt
10	3	7238*12	Oring Male Plug Socket Head(-12)
11	4	12112	Hex Bolt
12	1	12312	Hex Bolt
13	14	51634	Hex Bolt
14	12	58112	Hex Bolt
15	1	108881	Guard
16	1	108886	Splined Drive Shaft
17	2	108888	D60B15H Sprocket 138 Splined 21
18	1	108890	Idler Shaft
19	1	108910	Shield Spacer
20	1	108911	Lifting Lug
21	1	108915	Chain Guard
22	1	115597	Tightener Tube
23	1	116398	Trail Pro Weldment 50
24	1	116400	Rotor 50
25	1	116409	Shaft Guard 50
26	1	116429	Guard 60
27	1	116431	Guard-MIR 60
28	1	117956	Drive Shaft 50
29	1	120000	Chain Tightener 80
30	1	141922	T40-091 1-3/8x6 Shear Bolt-1-3/8x6 Slide Collar QD
31	1	GF	1/16 NPT ST Zerk
32	6	HSH-137	Heavy External Snap Ring
33	2	M12x1.75x30	Metric Bolt
34	6	M12x1.75x40	Metric Bolt
35	2	PL-150	Power Lock
36	1	R1400151	1 to1 Gearbox 78 hp@540
37	3	UCF208-108	4 Bolt Flange Bearing

Disc Left

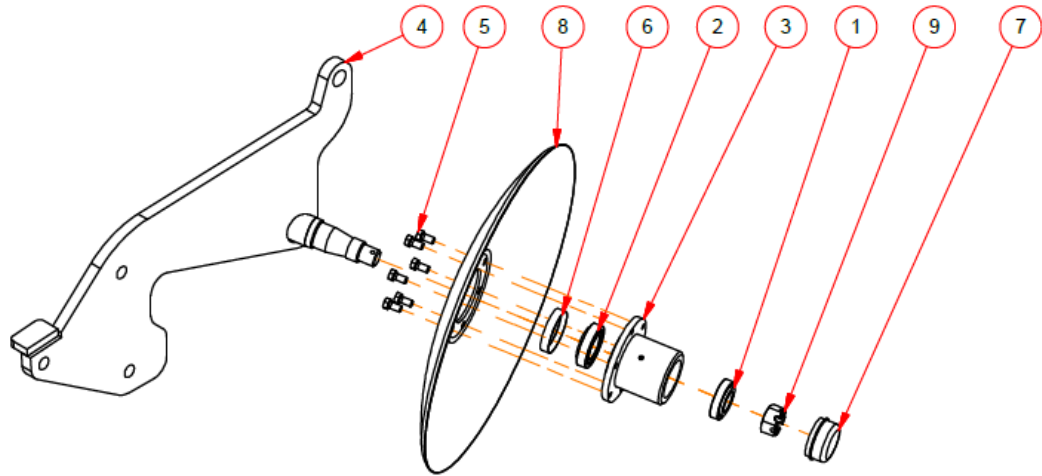

109389
Disc Arm Assembly Left

Parts List			
ITEM	QTY	PART NUMBER	DESCRIPTION
1	1	1.25 x 2.328 x 0.625 - LM67045 LM67010	Tapered Roller Bearing
2	1	1.5 x 2.5625 x 0.71 - LM29749 LM29710X	Tapered Roller Bearing
3	1	109385	Hub
4	1	109387	Disc Arm Left
5	6	3834	Hex Bolt
6	1	CR17415	SEAL
7	1	D4000	Dust Cap
8	1	PF20071814-RM	Disc 20in Flat center Modified
9	1	SJ-114	Slotted Hex Nut

Disc Right

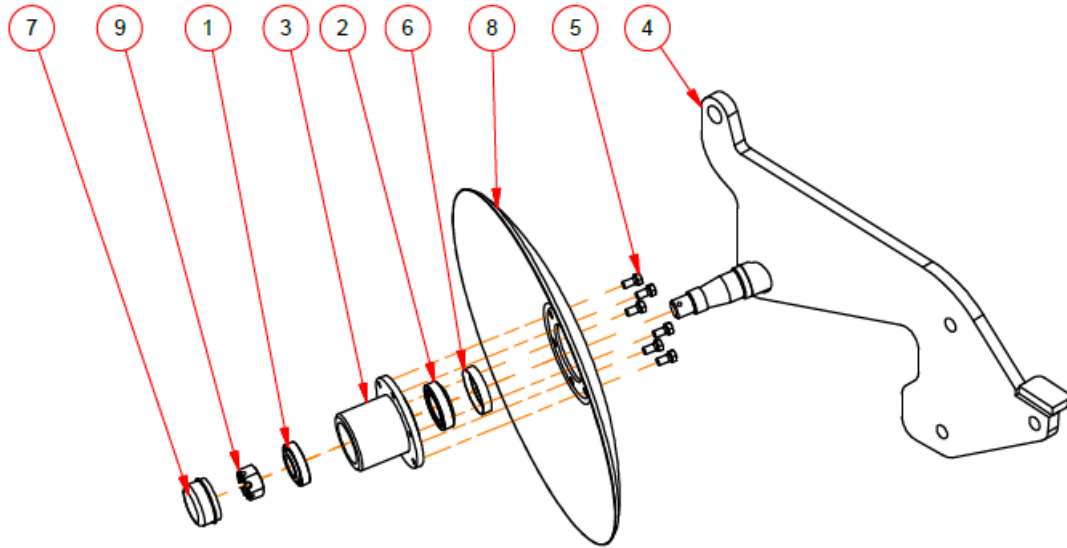

109388
Disc Arm Assembly Right

Parts List			
ITEM	QTY	PART NUMBER	DESCRIPTION
1	1	1.25 x 2.328 x 0.625 - LM67045 LM67010	Tapered Roller Bearing
2	1	1.5 x 2.5625 x 0.71 - LM29749 LM29710X	Tapered Roller Bearing
3	1	109385	Hub
4	1	109386	Disc Arm Right
5	6	3834	Hex Bolt
6	1	CR17415	SEAL
7	1	D4000	Dust Cap
8	1	PF20071814-RM	Disc 20in Flat center Modified
9	1	SJ-114	Slotted Hex Nut

Stone Guard Screen

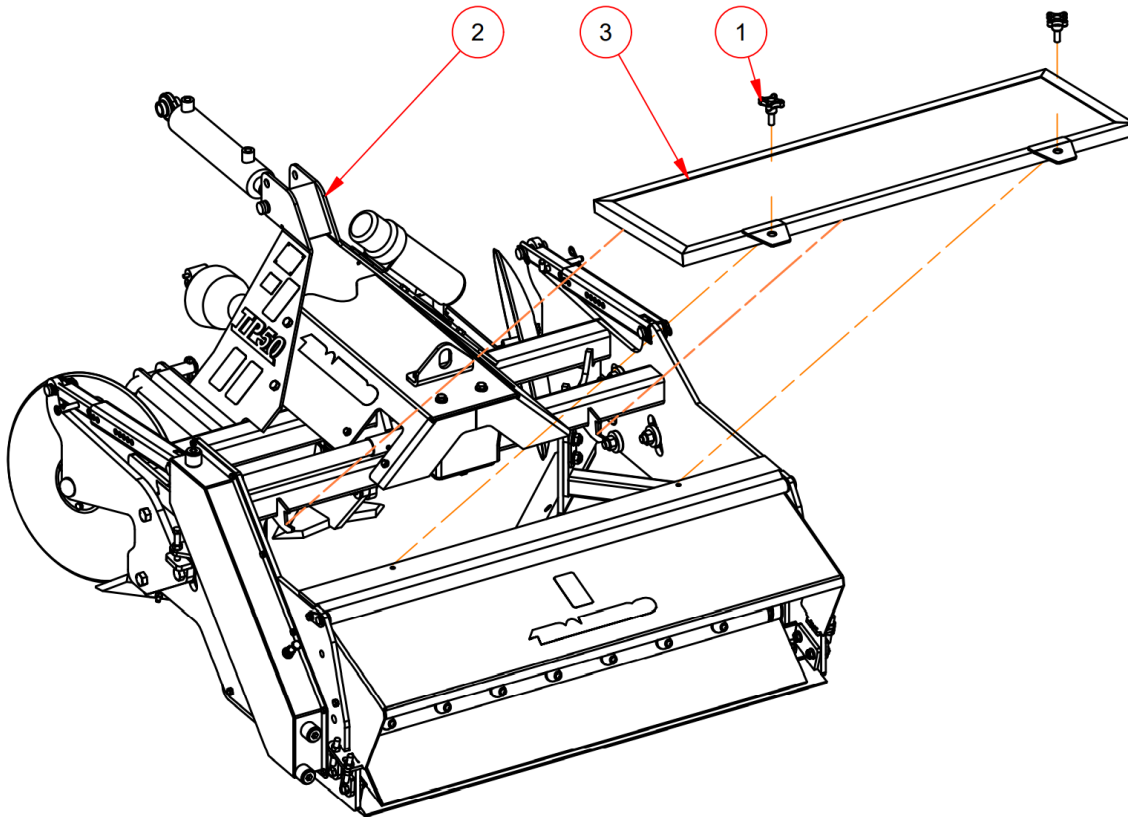

Parts List			
ITEM	QTY	PART NUMBER	DESCRIPTION
1	2	135-052	Knob
2	1	116398	Trail Pro 50
3	1	124477	Stone Guard Screen 50

Optional Rear Gauge Roller

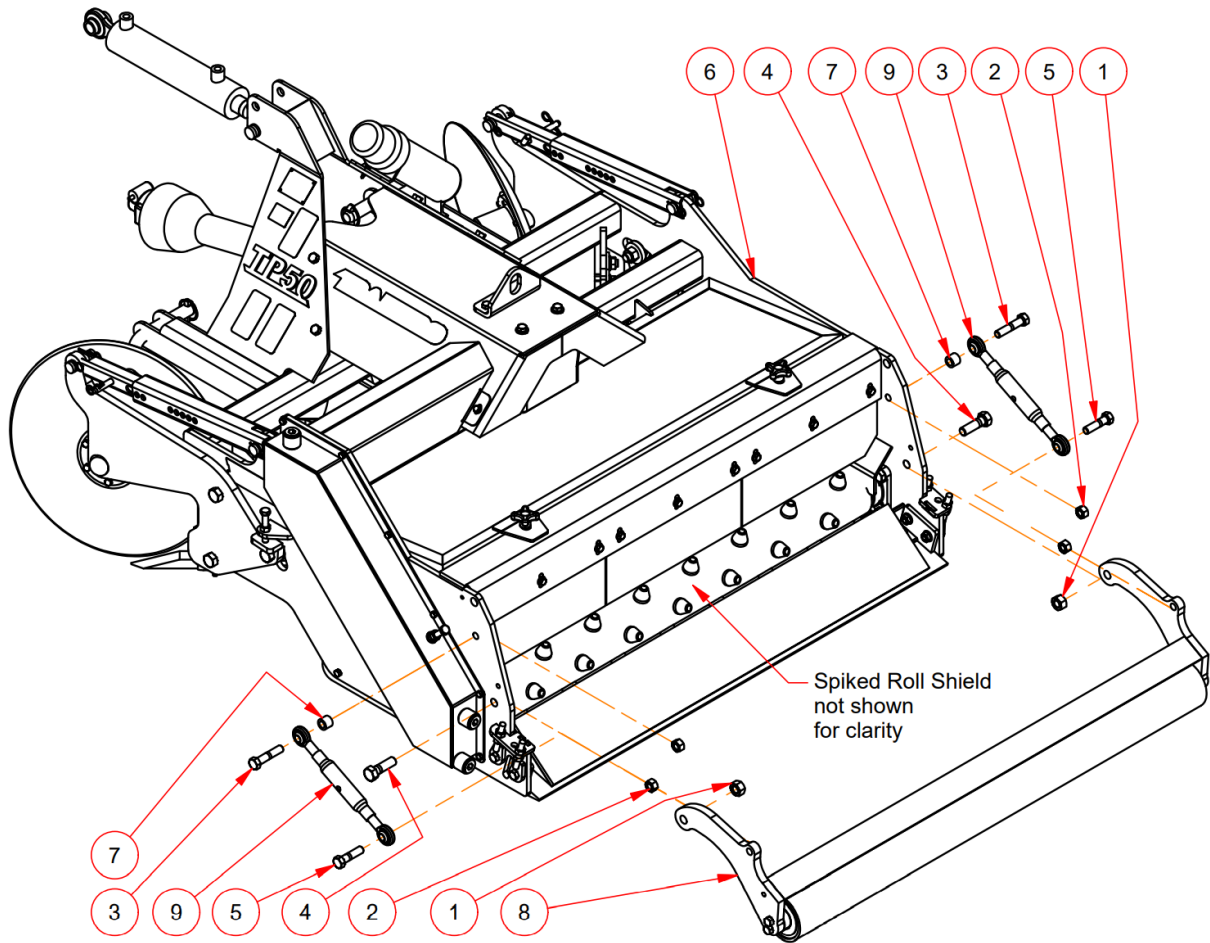

Parts List			
ITEM	QTY	PART NUMBER	DESCRIPTION
1	8	34N	Hex Nut
2	4	58N	Hex Nut
3	2	583	Hex Bolt
4	2	34212	Hex Bolt
5	2	58212	Hex Bolt
6	1	116398	Trail Pro 50
7	2	117594	Bushing
8	1	120938	TP50RR Roller Assembly
9	2	387601	Top Link Cat 0

WARRANTY INFORMATION

All new REIST machinery is warranted to be free from defects in material or workmanship, which may cause failure under normal usage and service when used for the purpose intended for a period of 12 months. This warranty applies only to a new REIST product, there being no warranty of any nature in respect to new products that have been modified or altered, repaired, neglected, or used in any way, which, in the opinion of REIST adversely affects its performance.

In the event of failure of a part or parts, and upon inspection, REIST is satisfied that failure is due to defective material or workmanship within 12 calendar months from the date of delivery to an end user, such defective part or parts will be repaired or replaced by REIST Industries Inc. It is the responsibility of the buyer, at his expense, to transport the machine or equipment to the manufacturer service shop or to an authorized service depot or, alternatively, to reimburse REIST for any travel or transportation expense involved in fulfilling this warranty.

When requested by REIST, part or parts shall be returned for inspection, transportation prepaid, to a place designated by REIST. IN NO EVENT SHALL THE BUYER BE ENTITLED TO RECOVER FOR INCIDENTAL OR CONSEQUENTIAL DAMAGES, INCLUDING, BUT NOT LIMITED TO, LOSS OF PRODUCT, INCONVENIENCE, RENTAL OR REPLACEMENT EQUIPMENT, LOSS OF PROFIT, OR OTHER COMMERCIAL LOSS.

This warranty becomes void and null if the equipment is modified, breaks down as the result of an accident, is not operated according to manufacturer's recommendations, damaged by negligence or if maintenance has not been carried out as specified.

THIS WARRANTY IS NOT TRANSFERABLE

REIST Industries Inc.
100 Union Street
Elmira, Ontario, Canada
N3B 2Z2

